

DMC Co., Ltd.

**Controller Board for Projected Capacitive Touch Screen
DUS3200 Product Specifications**

Table of Contents

1. Applicable Product	2
2. Product Specification	2
2.1. Touch Screen Board Specification	2
2.2. Host Interface	3
2.3. Electrical Specification	3
2.3.1. Maximum Absolute Rating.....	3
2.3.2. DC Characteristics	3
2.4. Connector Pin Assignment.....	5
2.4.1. Connector Information.....	5
2.4.2. Connector Terminal	5
3. Precautions	6
4. Change History	6
5. Warranty	7
5.1. Warranty Period	7
5.2. Warranty Target	7
5.3. Warranty Exceptions	7
6. Precautions for Use	8
6.1. General Handling	8
6.2. Others	8
Outline Dimensional Drawing	

1. Applicable Product

This specification sheet is applied to DUS3200 touch screen controller board.

2. Product Specification

2.1. Touch Screen Board Specification

Item		Spec	Remark
Touch Detection Principle		Projected Capacitive	
Host Interface		USB Full Speed UART	Compatibility with UART depends on firmware. Please check with our sales for compatibility.
Input Power-supply Voltage		4.75~5.25[V]	
Driving Voltage		18V	
Operating Temp		-40 [°C] to 85 [°C]	No dew condensation
Storing Temp		-40 [°C] to 85 [°C]	No dew condensation
Main IC		MCU 1 [pcs]	
		Sensor IC 2 [pcs]	
Number of Electrodes	Electrode (X)	78 (Max)	
	Electrode (Y)	52 (Max)	
Coordinate Performance	Normal Coordinate Number to Output	5 [Finger]	Maximum 20
	Report rate (1 finger)	100 [Hz]	*2
	Report rate (2 finger)	100 [Hz]	*2
	Report rate (2 finger at same axis)	100 [Hz]	*2
	Electrode resolution	256 [1/Electrode]	
	2 finger minimum distance (X)	3.5 [Electrode]	21[mm] @ 6[mm]◇
	2 finger minimum distance (Y)	3.5 [Electrode]	21[mm] @ 6[mm]◇
	Coordinate Accuracy (high accuracy area)	Max ±3.0mm	21.5inches or smaller*1
	Coordinate Accuracy (low accuracy area)	Max ±6.0mm	
	Coordinate Accuracy (high accuracy area)	Max ±5.0mm	21.6inches or larger *1
	Coordinate Accuracy (low accuracy area)	Max ±8.0mm	
	Low accuracy area	3 [Electrode]	Specify 3 areas from the edge
Low Power Mode		USB Suspend mode	
Calibration	Calibration function	Support	
	Calibration Time	Max 10 [sec]	*3

*1. Touch contact size: φ10. The indicated coordinate accuracies are performances under a noise-free environment. The accuracy may significantly drop due to extrinsic noises and surrounding environment.

*2. The indicated values depend on software noise filter and CR values of the sensor glass. This specification is of the operation by normal clock scan.

*3. Calibration Time varies according to size of the touch screen.

2.2. Host Interface

USB Interface

Item	Value	Note
Host Interface	USB 2.0 Full speed 12[Mbps]	
Power supply	Bus-powered	
Power type	High power device	
VendorID/ProductID	0x0AFA / 0x07D7 (At firmware update: 0x0AFA / 0x07D6)	
Power save mode	USB Suspend mode (compliant to USB specification)	Except current.

Serial Interface

Item	Value	Note
Host Interface	UART Baud Rate 57.6[Kbps]	
Data bits	8	
Stop bit	1	
Parity check	None	

2.3. Electrical Specification

2.3.1. Maximum Absolute Rating

Item	Specifications			Unit	Note
	Min.	Typ.	Max.		
Touch Panel Power Supply	-0.3		6	V	

2.3.2. DC Characteristics

Board Consumption Current

Test Condition: TA = 25°C, VCC = 5V

Item	Specifications			Unit	Note
	Min.	Typ.	Max.		
Touch Panel Power Supply	4.75	5	5.25	V	
Normal operation mode		95.0		mA	Report rate:100Hz 10 Finger, 23inch USB Vbus
Suspend mode		30.0		mA	

USB Signal (D+, D-) DC Characteristics

Parameter	Specifications			Unit	Note
	Min.	Typ.	Max.		
Input High Voltage	2.0	-	3.6	V	
Input Low Voltage	-	-	0.8	V	
Output High Voltage	2.8	-	3.6	V	
Output Low Voltage	0	-	0.3	V	

UART Signal (Rx, Tx) DC Characteristics

Parameter	Specifications			Unit	Note
	Min.	Typ.	Max.		
Input High Voltage (Rx)	2.0	-	3.6	V	
Input Low Voltage (Rx)	-	-	0.6	V	
Output High Voltage (Tx)	2.4	-	3.6	V	
Output Low Voltage (Tx)	-	-	0.4	V	

Reset DC Characteristics

Parameter	Specifications			Unit	Note
	Min.	Typ.	Max.		
Input High Voltage	2.3	-	3.6	V	
Input Low Voltage	-	-	0.9	V	
Minimum pulse width	1	-	-	ms	

2.4. Connector Pin Assignment

2.4.1. Connector Information

Connector Number	Model Number	Maker
CN1	SM06B-SRSS-TB	JST
CN2	SM11B-SRSS-TB	JST
CN4	FH28H-80S-0.5SH	Hirose
CN5	FH28H-80S-0.5SH	Hirose
CN6	FH28H-80S-0.5SH	Hirose
CN7	FH28H-80S-0.5SH	Hirose

2.4.2. Connector Terminal

Connector Number	Terminal Number	Terminal Name	Description
CN1	1	VBUS	USB power input
	2	D-	USB D-
	3	D+	USB D+
	4	GND	USB GND
	5	RESETn	Reset Terminal Active Low Minimum Pulse Width 1ms (Connection is unnecessary. It is pulled up within the board.)
	6	GND	Reset GND
CN2	1	ICE_CK	Unused
	2	ICE_DAT	Unused
	3	RESETn	Reset Terminal Active Low Minimum Pulse Width 1ms (Connection is unnecessary. It is pulled up within the board.)
	4	Tx	UART Communication DUS Board → Host Computer
	5	Rx	UART Communication Host Computer → DUS Board
	6	SCL	Unused
	7	SDA	Unused
	8	GPIO	Unused
	9	VCC_IN	DC Power Input
	10	ICE_VCC	Unused
	11	GND	Power GND
CN4			Connector for touch sensor, 55 pins
CN5			Connector for touch sensor, 80 pins

3. Precautions

Do not boot the controller while a hand or metal is on the touch panel. It may not work properly after booted. Operation may become unstable, depending on the surrounding environment.

Do not use the controller under environments that affect capacitance values (The affecting factors are such as power-supply noises).

The application tool, TPOffset must be executed before operating DMC's touch screens of capacitive multi-touch type (EXC series and DUS series) with the DUS series controller.

TPOffset is the application software executable on Windows. It can be downloaded from the DMC's website below.

DMC's website: TPOffset download page

<http://www.dmccoltd.com/english/download/tpoffset.asp>

4. Change History

Ver1.0 (June 21, 2018)

First release

Ver2.0 (May 28, 2020)

UART interface specifications have been added along with firmware support.

2.1. Touch panel board specifications Changed to standard output coordinates from 10 to 5 (for matching with other models)

2.3.2 The description of DC characteristics, current consumption and maximum current value has been deleted, and the notation has been changed to Typ.

Review the dimensional drawing and layout(There is no change in dimensions)

Ver3.0 (April 16, 2021)

2.1 Touch Screen Board Specification Added note on Host Interface

Revised operating temperature and storage temperature ranges

Revised coordinate accuracy specification values

2.3.2. DC Characteristics Added max values.

2.4.2. Connector Terminal

CN1: RESETn Added "(Connection is unnecessary. It is pulled up within the board.)".

CN2: RESETn Added "(Connection is unnecessary. It is pulled up within the board.)"

Tx/Rx Deleted "(5V TTL Level)".

3. Precautions Added a sentence

Dimensional Drawing Added components on backside of the board.

5. Warranty

5.1. Warranty Period

- § The warranty period is limited to 1 year from the date of shipping. The warranty for the initial deflection such as appearance deflection is limited to 1 month.
- § Any defected parts under proper use will be examined by the supplier and replaced by the new parts if the deflection is considered to be caused by the supplier.
- § The replacement is subject to be included in the next lot.

5.2. Warranty Target

- § The warranty only covers the product itself and does not cover any damage to others caused by using this product. Onsite repair or replacement is not supported.
- § We will do our best for delivery problem and product defections, but the warranty for the production line is not covered.

5.3. Warranty Exceptions

Following conditions are not covered with the warranty and subject to charge.

- § Any malfunctions and damages during transportation and transfer by the user.
- § Any malfunctions and damages caused by a natural disaster or a fire.
- § Any malfunctions and damages caused by static electricity
- § Any malfunctions and damages caused by the failure of the associated equipment.
- § If the product is remodeled, disassembled or repaired by the user.
- § If the product is glued onto the equipment and uninstalled.
- § Any malfunctions and damages caused by an improper usage and handling against the specifications and notes.

6. Precautions for Use

6.1. General Handling

- § Keep the product away from any conductive objects while in use.
- § Do not touch the conductive part of the product to avoid being damaged by the electrostatic discharge. Follow the proper procedure for handling.
- § Keep the product in the proper storing environment and avoid any load to the product.
- § Do not use or store the product in the severe condition like following:
Wet environment or a condition where the product is likely to get wet. Where dew condensation is likely to occur. Near solvent or acid.
- § Do not take apart or alter the product.

6.2. Others

- § The contents of this document are subject to change without notice.
- § The manufacturer or sales representatives will not be liable for any damages or loss arising from use of this product.
- § This product is intended for use in standard applications (computers, office automation, and other office equipment, industrial, communications, and measurement equipment, personal and household devices, etc.) Please avoid using this product for special applications where failure or abnormal operation may directly affect human lives, or cause physical injury or property damage, or where extremely high levels of reliability are required (such as aerospace systems, vehicle operating control, atomic energy controls, medical devices for life support, etc.).
- § Any semiconductor devices have inherently a certain rate of failure. The user must protect against injury, damage, or loss from such failures by incorporating safety design measures into the user's facility and equipment.

DUS3200 Product Specifications
Ver3.0 issued on April 16, 2021
©2021 DMC Co., Ltd.

This document can be freely distributed, but any alternation to this document is prohibited.



DMC Co., Ltd.

<http://www.dmccoltd.com/english/>

11F Takanawa Sengakuji Ekimae Bldg., 2-18-10 Takanawa, Minato-ku, Tokyo 108-0074, Japan
Phone: +81-3-6721-6731 (Japanese), 6736 (English) Fax: +81-3-6721-6732

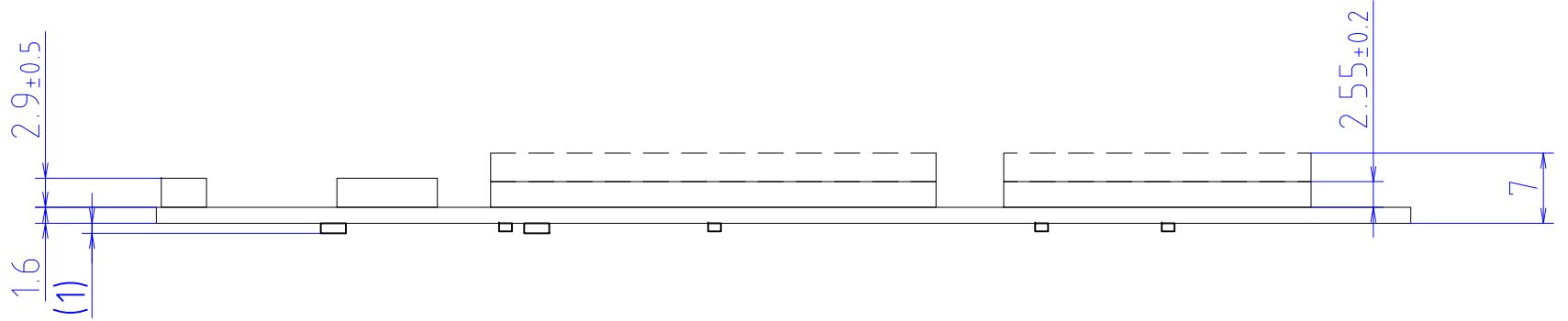
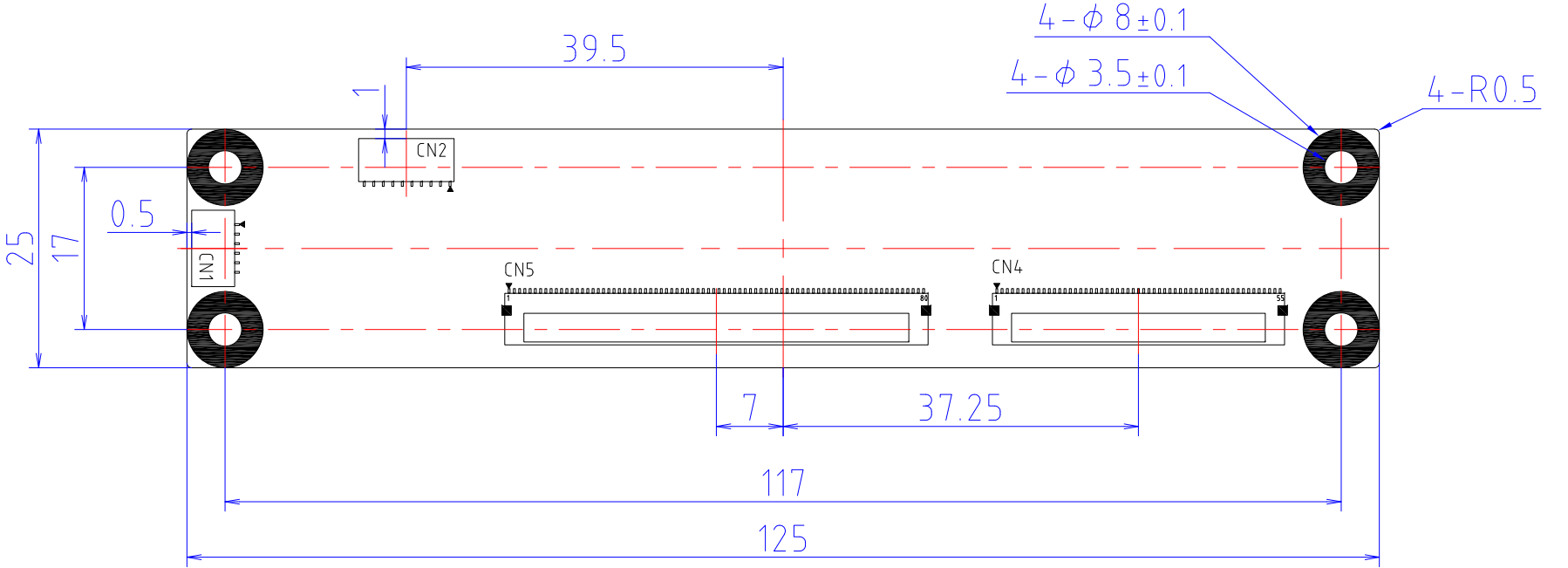

※ Tolerance: ± 0.3 except for hole diameter
 ※ Material: FR-4
 ※ Mass: Typ. 15g
 ※ Unit: mm

Date	P/N
January 6, 2021	DUS3200
Dimensional Drawing	
DMC Co., Ltd.	Rev.
	2