

## Product Outline: TK-SPA215FH-02, 21.5inch-wide PCAP Touch Module

Item	Specification		
	Display Size (Resolution)	Touch Panel Technology	Series
TK-SPA215FH-02	21.5" (FHD)	PCAP	Simple set

### 1 Assembly

Item	Specification	Manufacturer	Product model
LCD	21.5"	Innolux	G215HCJ-L01
Touch Panel	PCAP	DMC	DUS-LA215WA060A2A
Touch Controller	-	DMC	DUS3200

### 2 Outline Specifications

Item		Specification	Unit	
Display	Display Device	21.5" TFT LCD	-	
	Display Area (Active Area)	476.064(W)×267.786(H)	mm	
	Resolution	1920(W)×1080(H)	-	
	Pixel Pitch	0.248(W)×0.248(H)	mm	
	Support Color	Approx. 16.77M	color	
	Luminance (Typ.)	400 (LCD only) 350(With touch panel)	cd/m <sup>2</sup>	
	Viewing Angle (Typ.)	Vertical	89 / 89 (Upper/Lower)	deg.
		Horizontal	89 / 89 (Left/Right)	
	Interface	DUAL LVDS (24bit)	-	
	Backlight	LED, Backlight driver included	-	
Backlight life*1	Min 50,000	hour		
Touch panel	Touch Panel Technology	Projected capacitive touch panel	-	
	Input	Finger	-	
	Number of Multi-touch Points	5 points	-	
	I/F	USB 2.0	-	
	Supported OS	Windows XP/7/8/8.1/10(DMT-DD) Linux	-	
	Operating Life (input by finger)	50 million	Time	
Module	Bonding Method	Air-gap bonding	-	
	External Dimensions (Protruding parts not included.)	526.4(W)×330.3(H)×18.94(D)	mm	
	Operating Temperature	0 ~ 60	°C	

\*1 The time until the backlight brightness decreases to 50% of the initial value when it is continuously lit with the maximum brightness under the ambient temperature of 25°C.

SYM	改訂日 DATE	改訂内容 DESCRIPTION	ページ PAGE	担当 DESIGNED
	2021.05.24	新規図面登録	-	M.Mitani

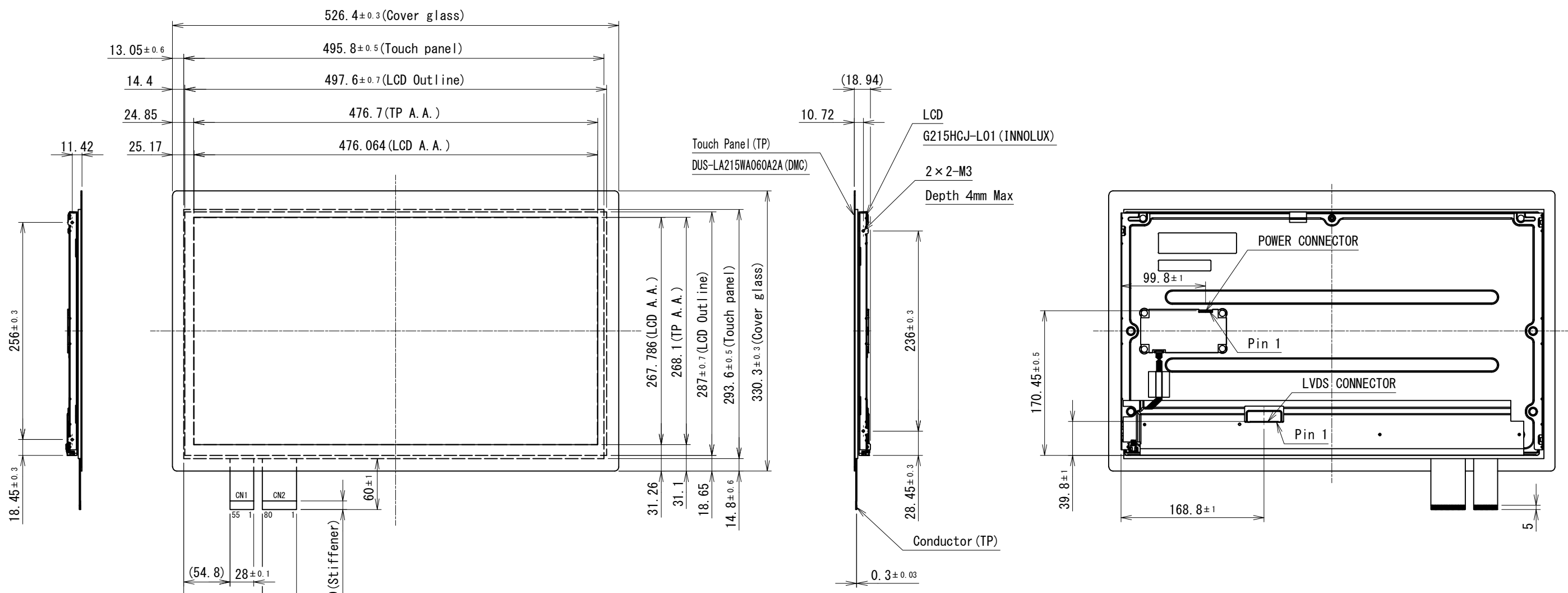

- NOTES
- タッチ方式：投影型静電容量方式
  - カバーガラス：厚さ1.1mm
  - Connector (POWER)：MS2409HJ (STM) or equivalent
  - Connector (LVDS)：187098-30091 (P-TWO) or WF13-422-3033 (FCN) or GS23301-0321R-7H (Foxconn)
  - 指示無き寸法公差は、±0.5mmとする。

製図日 ISSUED	2021.05.24	部署 SECTION	Technical Dept.	尺度 SCALE	CAD登録名 CAD FILE NAME	OUTLINE_TK-SPA215FH-02	RoHS対応品 RoHS compliant
承認 APPROVED		検図 CHECKED		1:5	製品名 MODEL	TK-SPA215FH-02	
		製図 DRAWN		単位 UNIT	図名 TITLE	OUTLINE	ページ PAGE
T.Okada	S.Yoshimoto	M.Mitani	M.Mitani	mm			1 / 1
 株式会社 シーズウェア				A3	図番 DWG No.	SM3-002267-10	