

Contents in this document may change without prior notice.
Please obtain the delivery specification for the final design.

Seedsware

EM Series
10.1" Wide
24VDC
Linux/ Touch Panel Embedded
Open Frame Panel Computer

EM8

Model: EM8-W310A7-0024-207

Product Specification

Seedsware Corporation
<http://www.seedsware.co.jp/global/>

Table of Contents

1.	Summary.....	3
2.	Product Model.....	3
3.	Packaged Contents.....	3
4.	Specification.....	4
4-1	Functional specification.....	4
4-2	Display Specification.....	5
4-3	Touch Screen Specifications.....	5
4-4	General Specification.....	6
4-5	Environmental Specification.....	6
4-6	Installation Specification.....	6
4-7	Names of parts.....	7
4-8	External Interface.....	8
4-8-1	microSD card slot.....	8
4-8-2	Serial Interface (SIO1/SIO2).....	8
4-8-3	Ethernet.....	9
4-8-4	USB Host Interface.....	9
4-8-5	USB Device Interface.....	9
4-8-6	DIO Interface.....	10
4-8-7	SPI/PWM Audio Interface.....	11
4-8-8	Power Connector.....	11
4-8-9	Battery Interface.....	12
4-8-10	Default Factory Switch Setting.....	12
4-9	Linux OS Specification.....	13
4-9-1	Application Software Development Environment.....	13
4-9-2	Embedded Application.....	13
4-9-3	IS-APP.....	13
5.	Installation.....	14
5-1	Installing condition.....	14
5-2	Mounting.....	14
5-2-1	Panel mounting.....	14
6.	Product label.....	15
7.	Compatible Standards.....	15
7-1	RoHS Directives.....	15
8.	List of Option.....	16
9.	Warranty.....	17
9-1	Warranty Period.....	17
9-2	Warranty Exceptions.....	17
10.	Production Discontinuance.....	17
11.	Others.....	18

Appendix : Outline drawing SM3-002153-10

1. Summary

This specification describes the panel computer with a 10.1" LDC touch panel.

Touch Screen line up includes analog resistive.

The panel computer will be referred to as EM8 hereinafter

2. Product Model

Part number	Specification			
	LCD size	Touch Screen Type	Power supply	HMI application
EM8-W310A7-0024-207	10.1"	Resistive	24VDC	IS-APP *1

*1 Please purchase the development kit (SWDK-101), when using HMI application "IS-APP"

For details, please refer to the IS-APP startup guide

3. Packaged Contents

Content	Specification	Packaging Box Dimensions
• EM8	5 units/box *1	356(W) × 296(D) × 210(H) mm

*1 : Maximum unit per package : 5 units

4. Specification

4-1 Functional specification

Item		Specifications	
		EM8-W310A7-0024-207	
CPU		NXP i.MX6ULL 792MHz (ARM Cortex-A7 single core)	
RAM		DDR3-SDRAM 512MB	
ROM		NAND Flash 512MB	
Interface	Serial	SIO1	RS232C : 1CH (5-pin nylon connector)
		SIO2	RS422/485: 1CH (6-pin nylon connector)
	Ethernet		10BASE-T/100BASE-TX : 1CH
	microSD Card ^{*1}		microSD/SDHC card slot : 1CH
	USB host ^{*2}		USB2.0 : 1CH (TYPE-A connector) USB devices that can be used : keyboard, mouse(HID Class), USB memory (Mass Storage Class)
	USB device		USB 2.0 : 1CH (miniTYPE-B connector)
	DIO		D IN : 4 points (Non isolated TTL Schmitt Trigger Input) D OUT : 4 points (Non isolated open collector output) (12 pin Nylon connector)
	SPI/PWM Audio		SPI/PWM Audio OUT: 1CH (7pin Nylon connector) SPI and PWM audio cannot be used at the same time.
	Buzzer		On board
	RTC ^{*3}		RTC with a battery backup Error at the time of backup :±65 seconds/month (Conditions: ambient temperature 25°C)

*1 Does not guarantee accurate operation for all SD memory cards available in the market.

*2 Does not guarantee accurate function for all USB devices available in the market.

*3 Above chart shows RTC with battery back-up embedded on the EM8.

EM8 normally uses timer inside the CPU for time display.

If time according to specification is needed, please refer to RTC built-in the EM8.

When using in system where time error becomes a problem, please set to correct time on a regular basis.

4-2 Display Specification

Item		Specifications
		EM8-W310A7-0024-207
Display	Type	10.1" TFT LCD
	Resolution	1024(W)×600(H)
	Color	65,536 colors
	Backlight	LED (not replaceable)
	Brightness	360cd/m ²
	Backlight brightness adjustment	Adjustable in 8 levels
	Backlight life *1	50,000 hours average

*1 Time until brightness declines by 50% from the initial value at maximum brightness in ambient temperature of 25°C.

4-3 Touch Screen Specifications

Item		Specifications
		EM8-W310A7-0024-207
Type	Analog resistive	
Input Type	Finger	
Multi-touch	1 point	
Operating life	Continuous typing (finger input) : 1 million times	

*1 Application for two point simultaneous input must be created by customer.

4-4 General Specification

Item		Specification
		EM8-W310A7-0024-207
Power	Rated voltage	24VDC
	Voltage tolerance	24VDC±20%
	Power consumption*1	6W or under (Typ. 4.5W)
	FG Connection	FG (Frame GND) and SG (Signal GND) are connected inside the unit

*1 Power consumption of the unit only. Please consider the power consumption of the USB device when using the USB.

Note: When power supply with slow rising and falling of power, it may not operate properly.

Also, when rebooting EM8, leave the power OFF for a while and do not turn the power back on immediately. It may not start up accurately when turned ON immediately.

4-5 Environmental Specification

Item		Specification
		EM8-W310A7-0024-207
Ambient operating temperature (Inside cabinet and display side)	0°C to 55°C	
Ambient storage temperature	-20°C to +80°C	
Ambient operating humidity	10%RH to 90%RH (Non-condensing. Wet-bulb temperature is 39 °C or less)	
Ambient storage humidity	10%RH to 90%RH (Non-condensing. Wet-bulb temperature is 39 °C or less)	
Dust	0.1mg/m ³ or under (Conductive dust is prohibited)	
Corrosive Gas	Corrosive gas Prohibited	
Environment	Pollution Degree 2, for Indoor use	
Pressure resistance	800hPa to 1114hPa (Altitude up to 2000m)	
Vibration resistance	IEC61131-2(JIS B 3502) compliant 5Hz to 9Hz Single amplitude 3.5mm 9Hz to 150Hz Fixed acceleration 9.8m/s ² X,Y,Z directions for 10times(100min.)	

4-6 Installation Specification

Item		Specification
		EM8-W310A7-0024-207
Grounding	Functional grounding : D type ground	
Structure	Open frame	
Cooling	Natural cooling	
Weight	Approx,770g	
External Dimensions	244(W) × 147(H) × 32.4(D) mm	
Outline drawing	SM3-002153-10	

4-7 Names of parts

■ Back: EM8-W310A7-0024-207

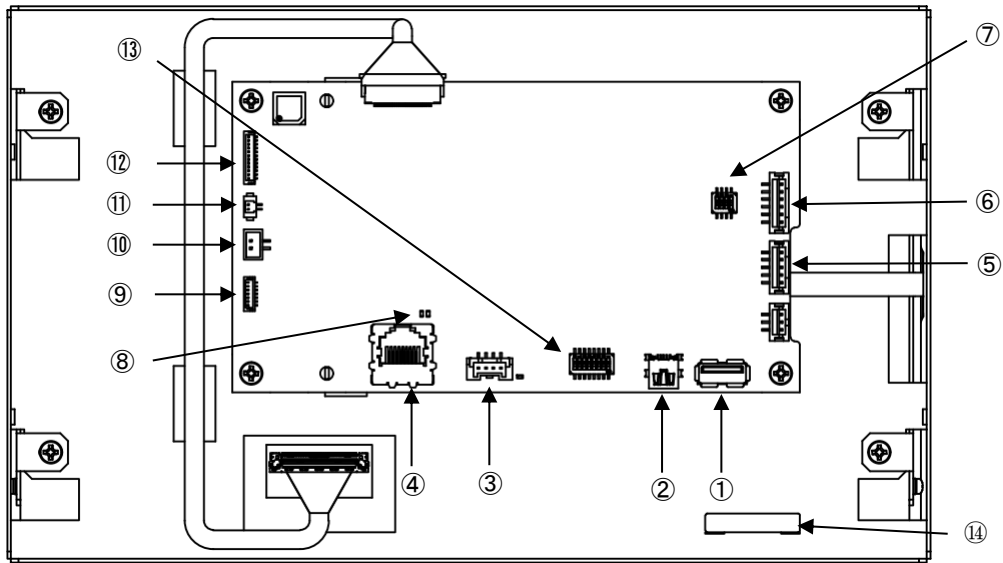

- | | |
|-----------------------|---------------------------------|
| ① USB Host | ⑧ Status LEDs for Ethernet Port |
| ② USB Device | ⑨ SPI/PWM audio |
| ③ Power Input | ⑩ Battery Input 2 |
| ④ Ethernet | ⑪ Battery Input 1 |
| ⑤ Serial Port (SIO1) | ⑫ DIO |
| ⑥ Serial Port (SIO2) | ⑬ Shipping setting switch |
| ⑦ SIO2 setting switch | ⑭ Product label |

■ Top: EM8-W310A7-0024-207

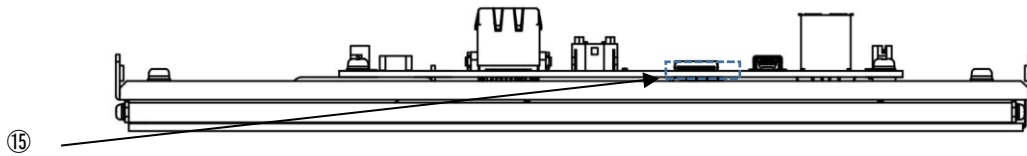

- ⑮ microSD Card slot

4-8 External Interface

4-8-1 microSD card slot

Connector: microSD card slot (Push-in/Push-out method)

Corresponding media: microSD/SDHC memory card

Maximum capacity: 32GB

4-8-2 Serial Interface (SIO1/SIO2)

(1) Serial port (SIO1): RS232C

Connector: Nylon connector

Recommended model: B5B-PH-SM4-TB (JST)

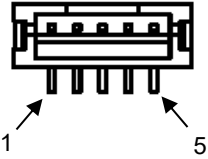
PIN No	Signal	Schematic
1	RXD	
2	TXD	
3	GND	
4	RTS	
5	CTS	

(2) Serial port (SIO2): RS422/485

Connector: Nylon connector

Recommended model: B6B-PH- SM4-TB (JST)

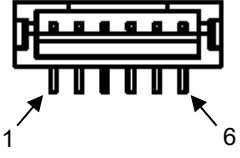
PIN No	Signal		Schematic
	RS422	RS485	
1	TX+	DATA+	
2	TX-	DATA-	
3	GND	GND	
4	RX+	(DATA+) ^{*1}	
5	RX-	(DATA-) ^{*2}	
6	GND	GND	

*1 Connected to pin 1 inside the product.

*2 Connected to pin 2 inside the product.

RS422/485 setting can be done with SIO2 setting switch

Default setting at shipment is "RS485 Terminating resistance enabled"

PIN No	RS422	RS485	Detail
1	ON/OFF		ON: Terminating enable / OFF: disable
2	OFF	ON	RS422/485 setting
3	OFF	ON	
4	OFF	ON	

4-8-3 Ethernet

Ethernet: 10BASE-T/100BASE-TX

Connector: RJ-45

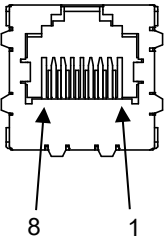
PIN no	Signal	Schematic
1	TX+	
2	TX-	
3	RX+	
4	NC *1	
5	NC *1	
6	RX-	
7	NC *1	
8	NC *1	

*1 NC is not connected

Status LED

GREEN : LINK/ACT

YELLOW : SPEED

*Status LED is located on board

Compatible cable: Above Category 5

4-8-4 USB Host Interface

Interface: USB2.0

Connector: Type-A connector

Maximum supply current: 0.5A

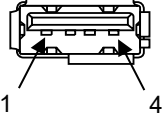
PIN No	Signal	Schematic
1	USB_VCC	
2	D-	
3	D+	
4	GND	

4-8-5 USB Device Interface

Interface: USB2.0

Connector: Type-B Mini connector

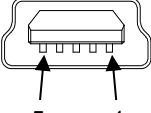
PIN No	Signal	Schematic
1	USB_VCC	
2	D-	
3	D+	
4	NC*1	
5	GND	

*1 NC is not connected

4-8-6 DIO Interface

Interface: DIO

Connector: Nylon connector

Recommended model: BM12B-SRSS-TBT (JST)

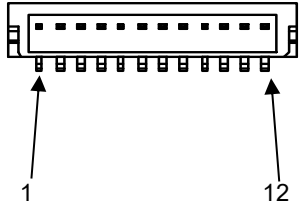
PIN No.	Signal	Schematic
1	DIN1	
2	DIN2	
3	DIN3	
4	DIN4	
5	GND	
6	GND	
7	DO_COM+	
8	DOUT1	
9	DOUT2	
10	DOUT3	
11	DOUT4	
12	DO_COM- (GND)	

◇D IN Specifications

Input Specification: Non-isolated TTL Schmitt trigger input

Number of Input Points: 4

Input Voltage +5VDC

Input Resistance: Pull up 10kΩ

Input Circuit:

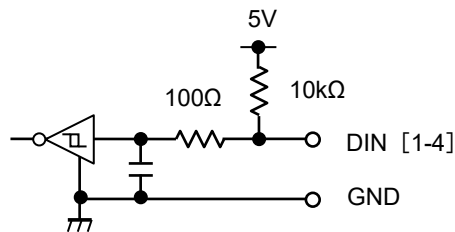

◇D OUT Specifications

Output Specifications: Non-isolated open collector output

Number of Output Points: 4

Output Tolerance: Maximum +5VDC

Output Current: Maximum 50mA (for each)

Output Circuit:

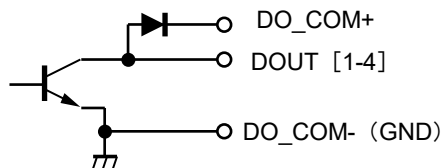

DO_COM is connected to the GND on the inside.

4-8-7 SPI/PWM Audio Interface

Interface: SPI/PWM Audio

Connector: Nylon connector

Recommended model: BM07B-SRSS-TBT (JST)

PIN No.	Signal		Schematic
	SPI	PWM audio	
1	CLK	-	
2	GND	GND	
3	CS	-	
4	MISO	-	
5	MOSI	MQS_RIGHT	
6	GND	GND	
7	5V OUT	5V OUT	

*SPI and PWM audio cannot be used at the same time.

◇SPI Specifications

In/Output signal level: Non isolated LVTTTL (3.3V)

◇PWM Audio Specifications

Audio output using MQS (Medium Quality Sound) function of the CPU.

Output is from the RIGHT (1CH) only.

Amplifier is not built in.

Please refer to below diagram for amplifier/speaker connection.

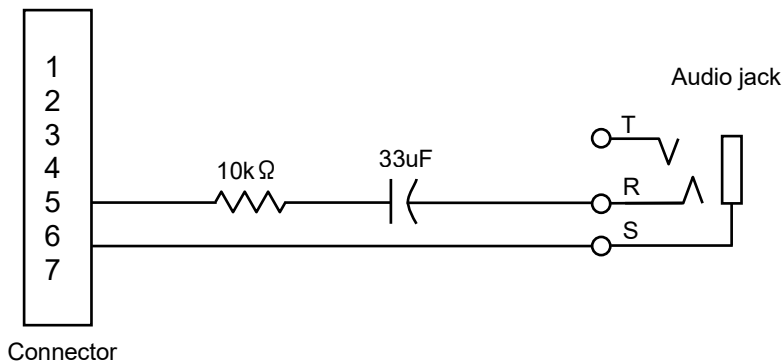

4-8-8 Power Connector

Interface: 24VDC IN

Connector: Nylon connector

Recommended model: BM02B-PASS-1-TFT (JST)

PIN	Signal	Schematic
1	GND	
2	24VDC	
3	(24VDC) *1	
4	(GND) *2	

*1 Connected to pin 2 inside EM8.

*2 Connected to pin 1 inside EM8.

4-8-9 Battery Interface

This product has two battery connectors.

When both are connected at the same time, the one with a higher voltage will take precedence.

Use the primary battery as the battery. Use the one with a nominal voltage of 3VDC.

Do not apply a voltage higher than 3.6VDC.

The backup current is TYP 60 μ A.

(1) Battery Interface 1

Connector: Nylon connector

Recommended model: DF13C-2P-1.25V(21) (Hirose electric)

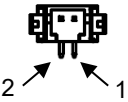
PIN	Signal	Schematic
1	+	
2	-	

* Recommended battery type: CR2032WK11 [capacity 220mA / h] (by Maxell)

* Primary batteries with a nominal voltage of 3VDC can be used with batteries other than those listed above.

(2) Battery Interface 2

Connector: Nylon connector

Recommended model: B2B-PH-SM4-TB (JST)

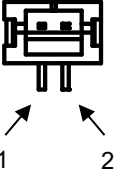
PIN	Signal	Schematic
1	+	
2	-	

* Recommended battery type: CR-2/3AZC22P [capacity 1,600mA / h] (by Panasonic)

CR17450 A WK 41 [capacity 2,500mA / h] (by Maxell)

CR17450 A 2WK 35 [capacity 5,000mA / h] (by Maxell)

CR17335 A WK 11 [capacity 1,650mA / h] (by Maxell)

* Primary batteries with a nominal voltage of 3VDC can be used with batteries other than those listed above.

4-8-10 Default Factory Switch Setting

This is a factory default switch setting. Changing the switch setting by the customer is prohibited.

EM8 factory settings

Shipping setting switch

No.	1	2	3	4	5	6	7	8
Set	OFF	ON	ON	OFF	ON	OFF	OFF	ON

4-9 Linux OS Specification

This describes the Linux OS embedded in the EM8.

For details, please refer to the EM series software development manual.

Software development environment (DVD) can be provided.

Please contact us via e-mail for the DVD.

By E-mail ✉ sales@uscoamerica.com

4-9-1 Application Software Development Environment

Qt application recommended

4-9-2 Embedded Application

Specification of Linux embedded in the EM8 are as shown below.

Item		specifications
Glibc version		2.23
Implementation software	Qt5.7.1	GUI tool kit
	PCMan File Manager	File manager
	GTK+	GIMP Toolkit library
	bash	Bash shell
	busybox	Program that places Linux basic commands in one file
	udhcpd	DHC client
	gdbserver	Gdb debugger that can connect from host
	ntpcient	Time synchronization by NTP
	Lighttpd	Web server: php and chi compatible
	x11	X Window system
	x11vnc	VNC server/client
	LXTerminal	Terminal emulator
	ALSA	Audio mixer
	emg-setting	EMG setting tool
	florence	Screen keyboard
	leafpad	Text editor
	openssh	SSH server
libmodbus	Modbus library	
FZLanTingHei-R-GB18030	RICHO (GB18030) font	

* For details, please refer to "EM series software development manual".

4-9-3 IS-APP

IS-APP (application version of the InfoSOSA) can be embedded to the EM8 as HMI application.

Please purchase the "Development Kit (SWDK-101) when using the IS-APP.

For details, please refer to "IS-APP start up guide"

5. Installation

5-1 Installing condition

- When mounting the EM8 to panels, be sure to have enough room for inserting and removing of microSD cards, cables, and mounting brackets.
- Please ensure ventilation and consider the specification temperature between EM8 and the structures and parts when installing the EM8.
- Be sure that the ambient operating temperature (0°C to 55°C) and the ambient humidity (10%RH to 90%RH. Wet-bulb temperature is 39°C or less) are within their designated ranges.
(Ambient operating temperature” indicates both the display side and inside of cabinet where the EM8 will be installed.)

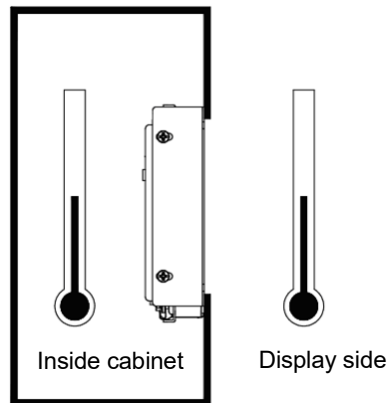

5-2 Mounting

5-2-1 Panel mounting

Below is the panel opening dimension example for when applying sheets and etc. to the surface by opening the entire touch screen surface.

Design the chassis accordingly to the actual installing method.

* Diagram from the front side of panel (panel thickness: 1.6mm or less)

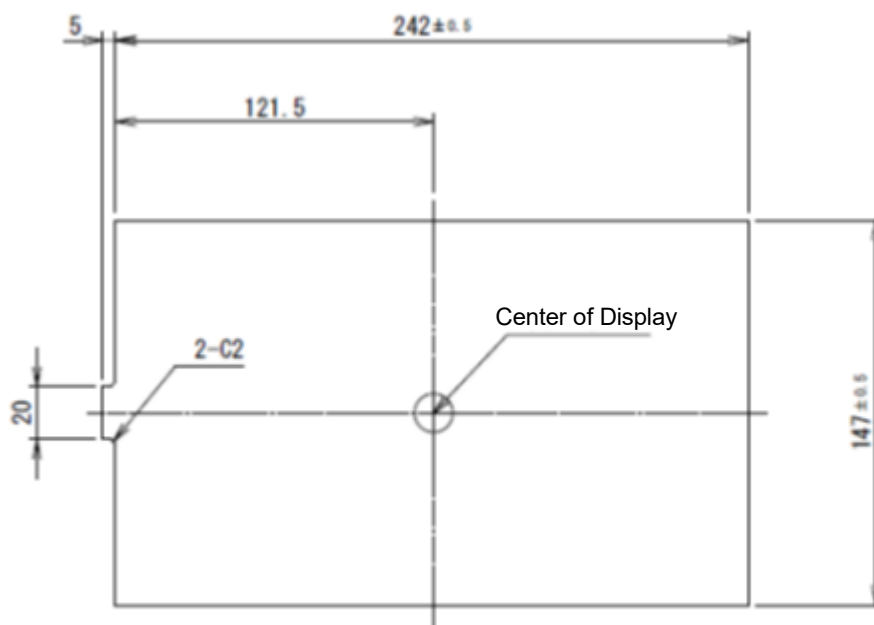

6. Product label

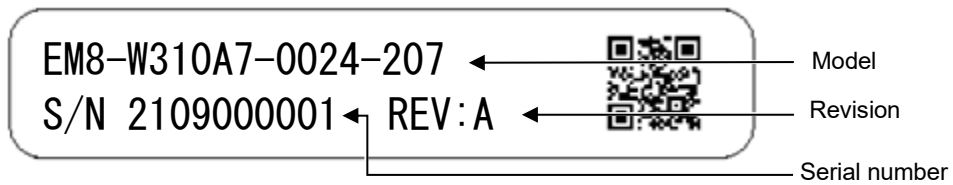

The above is an image of the Product label design

The product will be labeled with the following information

- Model name : The model of the product purchased.
- Serial number : The 10-digit control number assigned by us.
- Revision : The alphabet (1character) according to the latest shipping version.

7. Compatible Standards

7-1 RoHS Directives

This product is RoHS Directive of EU complaint

8. List of Option

■ Development Kit

Model	Description
SWDK-101	24VDC Power unit InfoSOSA Development Kit Data Download Guide *1

*1 This is needed when using InfoSOSA (IS-APP) application.

■ Serial Communication Cable

Model	Description
ISCBL-S02-001	RS232C Cable [Nylon connector 5P – D sub (2000mm)]
ISCBL-S03-001	RS232C Cable [Nylon connector 5P - cut end (500mm)]
SWHC-T2-001	RS422 Cable [Nylon connector 6P - cut end (500mm)]
SWHC-T3-001	RS485 Cable [Nylon connector 6P - cut end (500mm)]

■ Power Supply Cable

Model	Description
SWHC-P1-001	Power supply cable [Nylon connector 4P - Round terminal (500mm)]

9. Warranty

9-1 Warranty Period

The warranty period is limited to 12 months (1 year) from the date of shipment. Warranty for any repair needed to the same repaired part of the same product is three months. Any defects that occur upon normal use under conditions specified herein will be repaired (factory repair) free of charge.

Any defected parts under proper use will be examined by the supplier and replaced by the new parts if the defect is considered to be caused by the supplier.

The replacement is subject to be included in the next lot.

9-2 Warranty Exceptions

You will be liable for all repair fees even within the warranty period for any conditions listed below:

- (1) Any malfunctions, defects, and/or damages that occurred during transport, transfer, or mishandling by the user after delivery
- (2) Any malfunctions, defects, and/or damages caused by natural or man-made disaster.
- (3) Any malfunctions and damages caused by static electricity.
- (4) If the product is used under any condition, in any environment, or by any method other than those specified in the specifications, catalogs, manuals, notes, and/or other documents.
- (5) Any replacement of consumables.
- (6) Any malfunctions, defects, and/or damages caused by associated equipment and/or usage of inappropriate consumables and media.
- (7) If the product is repaired, remodeled, modified, or disassembled by a party other than Seedware
- (8) If the product cannot be identified by a serial number.
- (9) Any malfunctions, defects, and/or damages that are to have been caused on your behalf.

This warranty covers only the product itself. Any damages, on-site repairs and replacement driven by the failure of the product will be decided upon discussion by both parties as necessary.

This product is structurally not repairable. All damaged parts are subject for replacement and freight will be charged.

10. Production Discontinuance

In the event of production discontinuance, an announcement will be made on our website six months prior to the last possible order reception date.

11. Others

For comments or queries, feel free to contact us via e-mail.

By E-mail



sales@uscoamerica.com

FAQ



www.seedsware.co.jp/global/support/faq/

3rd Edition, September 2022

USCO America Inc.

136 W. Valletts Street, Elmhurst, IL 60126 USA

E-mail: sales@uscoamerica.com

Business hours: 9:00a.m. ~5:45p.m. (Central Time)

<http://uscoamerica.com/>

This document is protected by copyright law. Photocopying, duplicating, reproducing, and modifying of this product or document in part or by whole is prohibited.

寸法許容差 呼び寸法 Nominal Dimensions	TOLERANCE
L ≤ 3	±0.4
3 < L ≤ 6	±0.48
6 < L ≤ 10	±0.58
10 < L ≤ 18	±0.7
18 < L ≤ 30	±0.84
30 < L ≤ 50	±1.0
50 < L ≤ 80	±1.2
80 < L ≤ 120	±1.4
120 < L ≤ 180	±1.6
180 < L ≤ 250	±1.85
250 < L ≤ 315	±2.1
315 < L ≤ 400	±2.3
400 < L ≤ 500	±2.5

SYM	改訂日 DATE	改訂内容 DESCRIPTION	ページ PAGE	担当 DESIGNED
	2020.09.29	新規図面登録	—	S. Takada

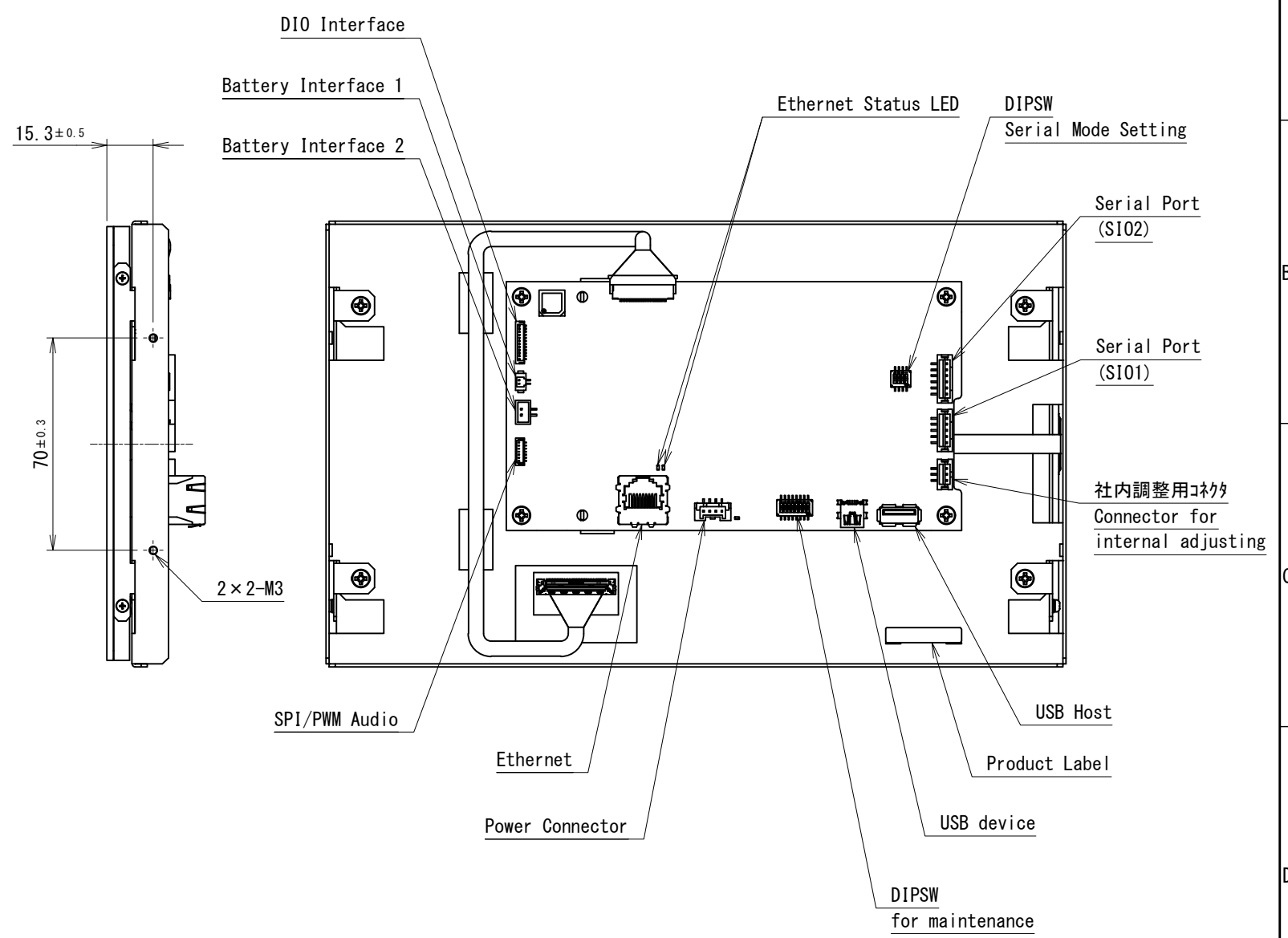
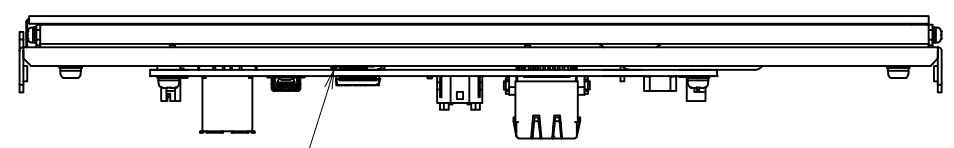
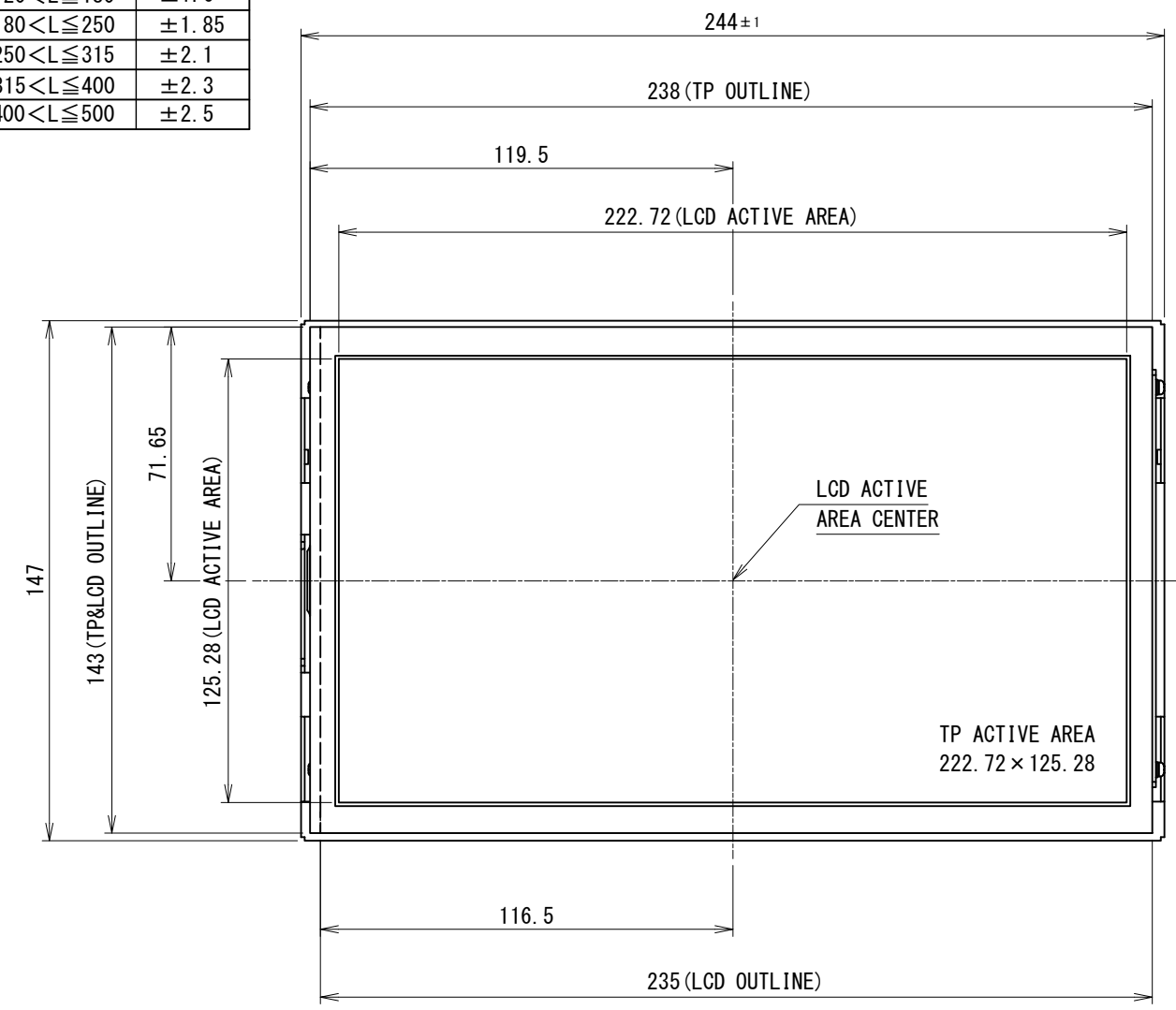
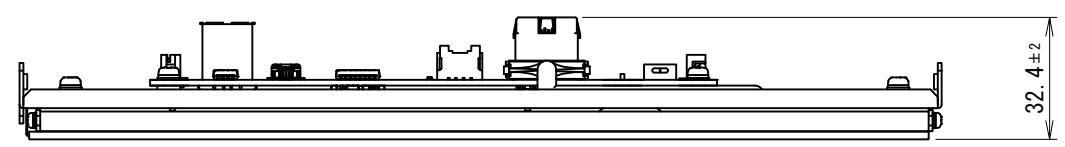

- NOTES
- 指示なき寸法公差は一般寸法公差とする。
Tolerance shall be of general dimensional tolerance unless specified otherwise.
 - 社内調整用コネクタは、お客様での使用はございません。
Connector for internal adjustment: cannot be used by customer.

製図日 ISSUED	2020.09.29	部署 SECTION	Technical Dept.	尺度 SCALE	CAD登録名 CAD FILE NAME	20K013-1_EM8-W310A7_OUTLINE	RoHS対応品 RoHS compliant
承認 APPROVED		検図 CHECKED		1:2	製品名 MODEL	EM8-W310A7-0024-207	
		製図 DRAWN	S. Takada	単位 UNIT	図名 TITLE	OUTLINE	ページ PAGE
T. Okada	S. Yoshimoto			mm			1 / 1
S. Takada			S. Takada		図番 DWG No.	SM3-002153-10	
Seedsware 株式会社 シーズウェア			A3				